

DATE
March 5, 2007
Cat. #: XPV0502C

OUTLINE DIMENSIONS

3-PHASE INDUCTION MOTOR

MOTOR TYPE:
AEUHXG
FRAME NO. 326TSC

Pole	HP	kW	Hz	VOLT	Syn. Speed r/min(rpm)
2	50	37.3	60	230/460	3600

Ins	Rating	Dimension in	Approx Weight	Bearings
F	CONT.	inch	766 lbs	DE: 6312C3 NDE: 6212C3

Totally Enclosed Fan Cooled Type. Squirrel-cage Rotor.

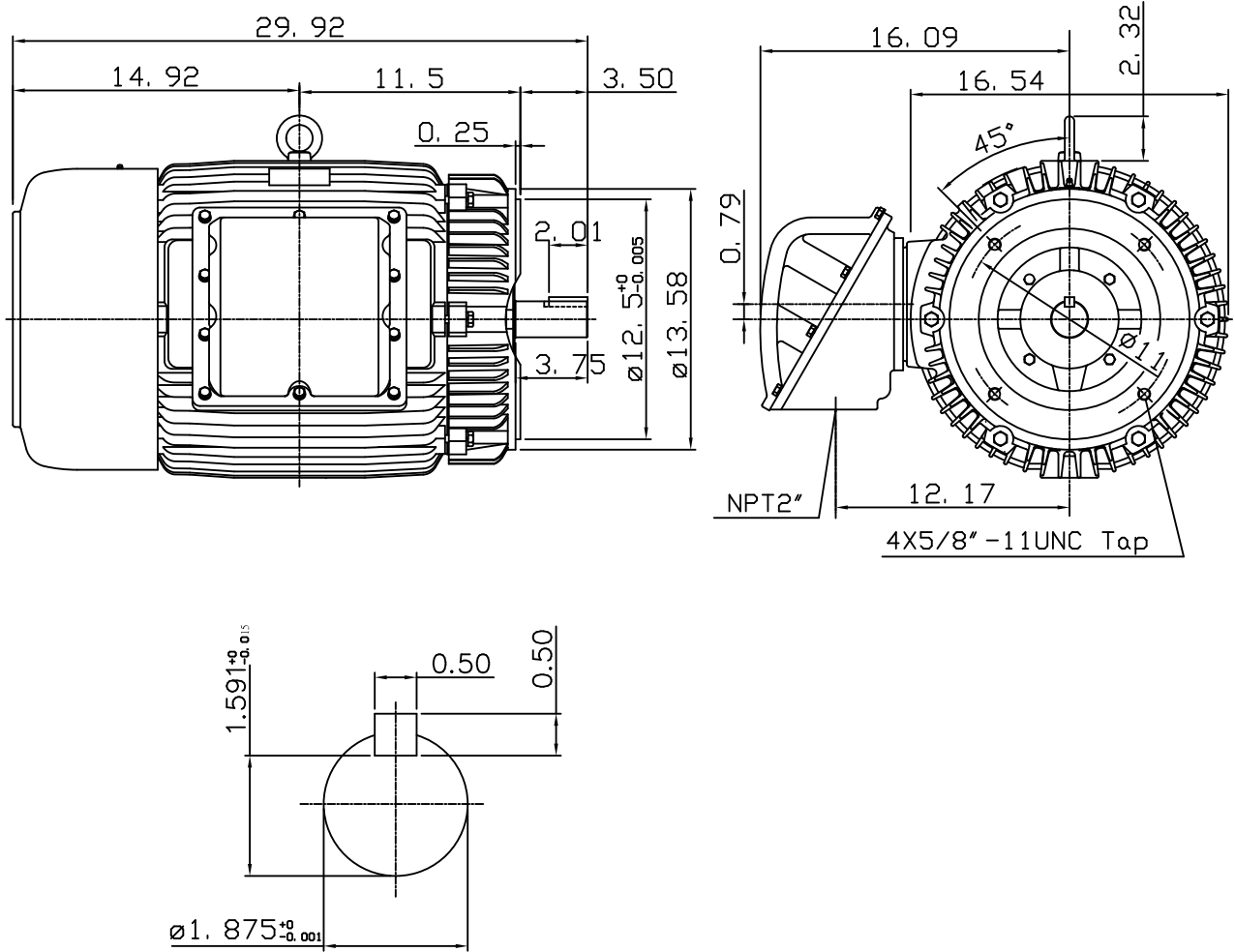

Note:
1. Suitable for division I,
class I Group D & class II
Group E, F, G, T2D or T3B.

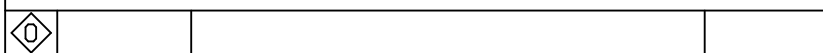

DWN.	G. L. GUD	05-28-03
CHKD.	C. H. KAO	06-06-03
APPD.	M. C. TSAI	06-06-03

TECO Westinghouse

DWG NO.
31049U563000